

MITSUBISHI FUSO
CANTER
EURO II **BUS**

THE FUEL EFFICIENT POWER BUS



MITSUBISHI FUSO CANTER

EURO II BUS



SPECIFICATIONS*

PERFORMANCE	
Max. Speed	100 km / hr.
Max. Gradeability	43.5%

ENGINE	
Model	4D34-2AT4 (EURO II)
Type	4 stroke-cycle, water cooled direct injection diesel with turbocharger & intercooler
Max. Output	136 HP @ 2900 rpm
Max. Torque	38 kgf.m @ 1600 rpm
Displacement	3907 cc

CLUTCH	
Type	Hydraulic control diaphragm spring single dry plate
Size	300 mm

TRANSMISSION				
Type	5 Forward + 1 Reverse OD Transmission, 2nd - 5th Synchronesh			
Gear Shift Lever	Joystick type (in dashboard)			
Ratios	1st	5.380	5th	0.722
	2nd	3.028	Reverse	5.380
	3rd	1.700	Final Gear Ratio	6.166
	4th	1.000		

AXLE	
Front	Reverse Elliot, "I" beam
Rear	Full floating type

BRAKES	
Service	Hydraulic with vacuum servo assistance, dual circuit
Parking	Internal expanding type on propeller shaft at rear of transmission
Exhaust	Vacuum operated, butterfly valve type

STEERING	
Type	Ball-nut type with integral type hydraulic power booster. Telescopic and tilt steering column with steering lock

SUSPENSION	
Type (Front & Rear)	Semi - elliptic, laminated leaf springs, hydraulic double acting telescopic type shock absorbers on front & rear axles

TYRE	
Size	7.50 - 16 - 14 PR
No. of Studs	6
No. of Tires	7 including 1 spare tire

FUEL TANK	
Capacity	100 Liters

ELECTRICAL SYSTEM	
Battery	2 x 12 Volt, 65 AH
Generator	24 Volt, 50 AMP

WEIGHT	
Gross Vehicle Weight	kg 8900
Kerb Weight	kg 2400

DIMENSIONS					
Wheelbase	mm	4550	Front Overhang	mm	1110
Overall Length	mm	8015	Rear Overhang	mm	3325
Overall Width	mm	2035	Chassis Weight	kg	2345
Tread Front	mm	1665	Front Axle	kg	1305
Tread Rear	mm	1560	Rear Axle	kg	1040
Ground Clearance	mm	210			

BODY SPECIFICATION	
Structure	Single deck, Hollow Square & rectangular tubes
Outer Skin	M.S. Sheet 1.2mm or 1mm
Front & Rear Panel	FRP Molded
Passenger Seats	32 Seats in 2x2 configuration
Overall Length	mm 8450
Overall Width	mm 2200
Room Height	mm 1810

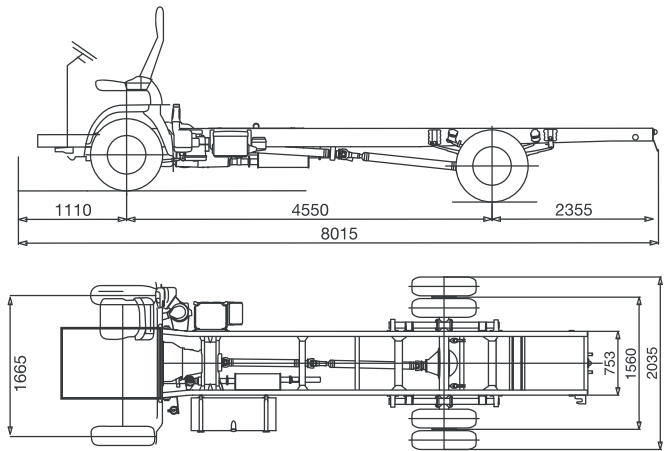

KEY FEATURES



Luxurious interior design with sound insulation to provide pleasant travelling experience for passengers.



Rear Emergency exit

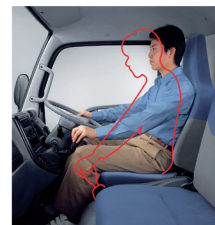

In-Dash Gearshift for easy and precise shifting.



4D34 Diesel Engine, 3907cc
Output 136HP
Torque 38 kgm



Collapsible & Tilting Power Steering makes steering an effortless task. The urethane foam of the steering wheel deforms to absorb impact energy thereby reducing the potential for injury to the chest.



The meter cluster is logically arranged & uses non-reflective curved glass to allow the driver to view all vital information at a glance. The odometer & trip meter have liquid crystal displays (LCD).



Equipped with optional Bus Stop Sign to meet international standards.